



# ZONDA hexapod

Very stable hexapod with high precision



## KEY FEATURES

- Very high stability
- Resolution 0.1  $\mu\text{m}$
- Payload capacity up to 500 kg
- Vacuum compatibility
- Large travel ranges

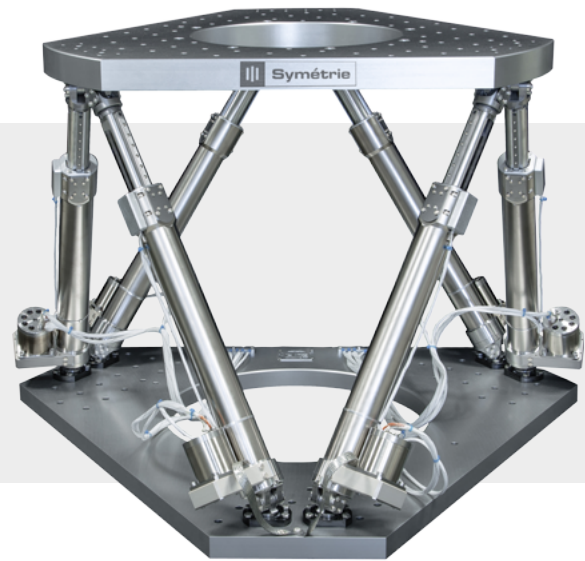

## APPLICATIONS

- Synchrotrons
- Metrology
- Optics
- Instrumentation
- Tests laboratories
- Aeronautics and space
- Semiconductors



A vacuum compatible ZONDA hexapod is used at CSL to calibrate space optical instruments.



ISO5 clean room compatible hexapod to test space optical instruments for MTG (Meteosat Third Generation) satellites at BERTIN Technologies.

ZONDA	
Motion and positioning	
Travel range Tx, Ty (mm)	± 200
Travel range Tz (mm)	± 150
Travel range Rx, Ry, Rz (deg)	± 20
Resolution Tx, Ty, Tz (µm)	0.1
Resolution Rx, Ry, Rz (µrad)	0.5
Repeatability Tx, Ty, Tz (µm)	± 0.5
Repeatability Rx, Ry, Rz (µrad)	± 2
Speed (mm/s; deg/s)	0.6; 0.04
Mechanical properties	
Stiffness X, Y (N/µm)	8.5
Stiffness Z (N/µm)	30
Payload capacity (kg) (vertical orientation / horizontal orientation)	400 / 140
Motor type	Stepper
Encoder type	Absolute linear encoder
Miscellaneous	
Operating temperature range (°C)	0 to + 75
Materials	Aluminum, stainless steel, Invar, Peek
Size mobile platform (mm)	Ø 720
Height in middle position (mm)	640
Mass (kg)	96
Cable length (m)	< 5
Options	Clean room compatibility Vacuum compatibility Customized platform design
Controller	
Controller type	ALPHA
Interface	Ethernet, USB
Power supply	110-240 VAC / 50-60 Hz

Datasheet subject to change without notice. All data are superseded by any new release. R160608

The performances are specified for single axis motions, with all other axes at midrange and for a rotation center in the middle of the mobile platform.

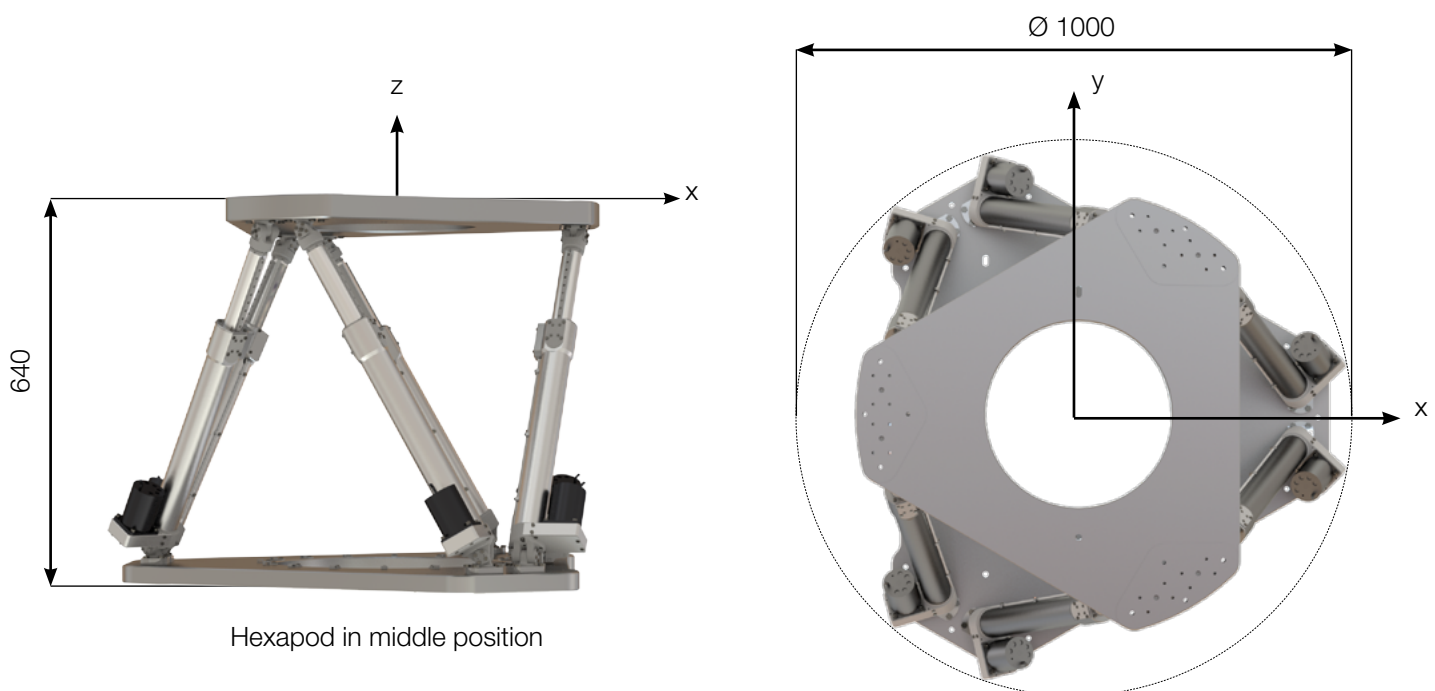

Hexapod in middle position